

# Victorian Bridge Association Bulletin

March 2014

Editor: Bill Jacobs

## GETTING TO KNOW THE LAWS

Have you ever looked at the Laws of Duplicate Bridge? It's a green book that runs to 113 pages and lists 93 laws. It is not for the faint-hearted. 93 laws doesn't sound too bad, until you come to the sub-sections. You might not want to know the details of, for example, Law 16, Section B, Part 1, Clause (a), but by hook or by crook, you need to abide by it.

In this on-going series, we will look at some of the more pertinent laws, as they apply to us as players. Think of it as the first draft of my forthcoming best-seller "Laws of Contract Bridge for Dummies".

Let's start with ...

### Director!

Like all competitive sports, Duplicate Bridge requires the presence of an umpire: a person in authority who applies the laws of the game. But unlike other sports, this umpire, the director, cannot be present all the time to observe and rule upon the play of the game.

He needs to be summoned when an application of the laws is required, due to some irregularity having occurred.

This is enshrined in Law 9:

*9. B. 1 (a) The director shall be summoned at once when attention is drawn to an irregularity.*

Here are three common examples where an irregularity has occurred:

1. East bids 2♦ and South bids 1♠ over it.
2. South detaches ♣10 from his hand and holds it just above the table, but before laying it down on the table, changes his mind and replaces it with the ♣A.
3. South bids 2♠ and after just a brief moment wants to change it to a 2♥ bid.

Do you know the correct ruling in each of these situations? Are you sure? Frankly, I doubt it.

The good news is that you don't have to know the correct ruling: you only have to recognise that an irregularity might have occurred. Call the director.

The further good news is that it can never cost you to call the director. Law 9 goes on:

*9. B. 1 (c) Summoning the director does not cause a player to forfeit any rights to which he might otherwise be entitled.*

But here is the real point of this article. Many players, particularly inexperienced players, get very flustered and upset when an opponent calls the director over their irregularity. This is sad, and a real problem for the game.

If your opponent calls the director when you do something irregular, this is *not* an accusation of bad behaviour, or heaven forbid cheating. It is an action required by the Laws. It is part and parcel of duplicate bridge: irregularities occur all the time - very few duplicate sessions would go by without at least one requirement to call the director.

Look at it this way: you could (and should) call the director regarding *your own* irregularity: it doesn't have to be an opponent calling.

South's actions in our three examples are irregularities - akin to holding the ball in AFL, or stepping in netball, or a false start in a sprint race. They happen - they are an intrinsic part of the game.

On the flip side, calling the director due to an opponent's irregularity should be done politely, and with only the decibels sufficient to get the director's attention.

To paraphrase a theme from last year: Do It Nicely!

**FOR STARTERS**  
**Bill Jacobs**

You hold:

♠ AQ ♥ 5 ♦ A10543 ♣ K8762

It is a matchpoint duplicate, no one is vulnerable and partner deals. The auction begins:

LHO	Partner	RHO	You
	Pass	1♠	?

Your bid.

---

This situation is tailor-made for the Unusual 2NT convention. A jump to 2NT over an opponent's opening bid of 1♠ or 1♥ is "unusual" in that it does not show a notrump hand. Instead it shows both minor suits, at least 5 of each minor. It is a fine way of showing both your suits in a single bid.

The strength required for the Unusual 2NT varies according to the vulnerability: non-vulnerable, you might have as few as about 8 HCP; if vulnerable you need to be considerably stronger, probably about 12 HCP would be an acceptable minimum.

You try the Unusual 2NT and the auction proceeds apace:

LHO	Partner	RHO	You
	Pass	1♠	2NT
4♠	4NT	Pass	?

What does 4NT mean, and what do you bid?

---

A bid of 4NT is often the Blackwood convention, asking for aces, but does that make sense here? Partner passed originally: how could she possibly have a hand that wants to go gallivanting off to the 6-level?

No, partner is not asking for aces: instead she wants you to name a minor. She is thinking that you might have 6-5 shape, and wants to play in the longer combined trump fit.

You bid 5♣ (the lower of your two suits, expressing no particular preference), and that ends the auction.

LHO leads ♠3 and this is what you see:

♠ 8
♥ J872
♦ KQ92
♣ Q543
N
S
♠ AQ
♥ 5
♦ A10543
♣ K8762

RHO plays ♠K. Plan the play.

---

Count your losers. None in spades, one in hearts, none in diamonds, and certainly the ace of clubs. So two losers – the main risk of another loser is in the club suit: you don't want to have to lose a second club trick.

If the outstanding 4 clubs divide 2-2, there will be no difficulty. One of your honours will force out the ace, and the other will clean up the rest of them.

At the other end of the scale, if clubs are 4-0, there is no hope. You will lose at least 2 club tricks and go down. But no-one doubled the final contract, so that scenario is unlikely.

Now what if the clubs are 3-1? If someone has AJ10 or similar, then you are going to go down.

The crucial situation, where your play *does* matter is if someone has ace singleton. You want to lead a low club *through* the hand with the singleton ace, so that ace will beat "thin air". Then the king and queen will deal with the remaining trumps.

Which of the opponents is more likely to have the singleton ace of clubs?

---

East opened the bidding: he has more points than West. So East is more likely to have the club ace than West.

You have won the ♠A at trick 1. What do you play at trick 2?

---

To protect against East having the singleton ace of clubs, you want to play the first round of trumps by leading a low club from dummy.

The only safe way to get the lead into dummy is to trump a spade at trick 2. Never mind that it is a winning spade! The correct and winning play is to trump the ♠Q at trick 2 and play a low club, the full deal being:

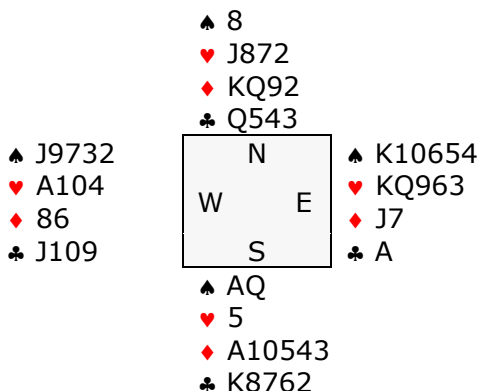

*Points to remember:*

- The Unusual 2NT is one of the more ancient gadgets, invented back in the 1960s. It's as good a convention now as it was then.

It's worth agreeing with your favourite partner what a 2NT overall of 1♣ or 1♦ shows. One simple option is that the 2NT overall shows the two *lowest* unbid suits. So after a minor suit opening, it would be hearts and the other minor.

- Sometimes it just takes a bit of sweat to work through the possible options when playing a suit.



**Suit Combination of the month**

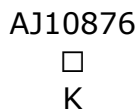

You need 5 tricks, but have only one entry to dummy (the hand with the 6 card suit). How do you go about it?

Solution on page 4.

**TEST YOUR BIDDING**

**Partner jump-raises you**

LHO	Partner	RHO	You
	1♣	Pass	1♥
Pass	3♥	Pass	?

When opener jump-raises your response, he is showing more than minimum opening values and 4-card support for you.

Now that a fit has been established, you can start counting distributional points: 1 for a doubleton, 3 for a singleton and 5 for a void, to give you total points (TP). Partner has done this already, and the jump raise indicates about 17 – 18 TP. Your options are:

With a really minimum hand, about 6 – 8 TP, pass: your combined assets are not enough for a game contract of 4♥.

With a stronger hand, 9 – 12 TP, bid 4♥.

If you have 13+ TP, you will want to consider a possible slam. There are two ways to approach this. With a really powerful hand, you can launch into 4NT, Blackwood, just to check that you are not missing two aces. Alternatively, you can make a *cue-bid*, a bid in a new suit, to show that you have first or second round control of that suit (the ace, void, king or singleton), and inviting partner's co-operation in a slam hunt. Because you have already established a heart fit, bidding another suit does not indicate you want to play in that suit, but is instead starting a slam investigation with hearts as trumps.

Count your total points and decide your rebid with the following hands.

- (a) ♠ 9765 ♥ AQ54 ♦ J64 ♣ 93
- (b) ♠ K976 ♥ AQ54 ♦ J64 ♣ 93
- (c) ♠ 52 ♥ AQ1054 ♦ KJ64 ♣ A9
- (d) ♠ 2 ♥ AJ10543 ♦ J64 ♣ 932
- (e) ♠ 2 ♥ AQ1054 ♦ KJ64 ♣ A93
- (f) ♠ AJ2 ♥ KJ10543 ♦ A643 ♣ -

Solutions over page.

**TEST YOUR BIDDING - SOLUTIONS**

LHO	Partner	RHO	You
	1♣	Pass	1♥
Pass	3♥	Pass	?

(a) ♠ 9765 ♥ AQ54 ♦ J64 ♣ 93

8 TP. Pass. This is a bare minimum response to 1♣, and you cannot expect to make 4♥.

(b) ♠ K976 ♥ AQ54 ♦ J64 ♣ 93

11 TP. 4♥. The extra king compared to hand (a) should be worth a trick.

(c) ♠ 52 ♥ AQ1054 ♦ KJ64 ♣ A9

16 TP. 4♣. There is every chance of making a slam here, but your two little spades present a problem. If partner has neither ♠A nor ♠K, you are open to losing the first two spade tricks. Your 4♣, showing control in clubs, includes a useful negative inference: because you by-passed a cue-bid of 3♠, you are denying a control in that suit. Partner can check her holding in spades and this will help her decide whether to participate in the slam investigation. For example, if she bids 4♥ now, you will know to pass.

(d) ♠ 2 ♥ AJ10543 ♦ J64 ♣ 932

9 TP. 4♥. Your singleton spade and six hearts represent a powerful combination. This hand is a "player". I admit I would bid 4♥ here even without one of the red jacks.

(e) ♠ 2 ♥ AQ1054 ♦ KJ64 ♣ A93

17 TP. 4NT. This hand surely should make slam unless partner doesn't have any aces. You don't have two fast losers in any side-suit. Use the Blackwood convention to check on the ace situation.

(f) ♠ AJ2 ♥ KJ10543 ♦ A643 ♣ -

18 TP. 6♥. Try for slam! There's no point using Blackwood here, because of your void. It doesn't matter whether partner holds 0, 1 or 2 aces: you still want to play in slam. It's possible that 6♥ will go down, but unlikely. Frankly, I think it more likely that a grand slam is making than small slam goes down, but there's no sensible way to root out a grand slam.

**SETTING TRICK PROBLEMS**

**Problem 1:**

Dlr: West ♠ J76  
 Vul: Nil ♥ 103  
 ♦ A10872  
 ♣ KQ10

N	♠ K543
W	♥ AQ7
E	♦ Q96
S	♣ J95

West	North	East	South
1♥	Pass	2NT <sup>1</sup>	3♠
4♦ <sup>2</sup>	4♠	D'ble	All Pass

- 1 raise to game
- 2 second suit

Partner leads ♥4 (fourth best).

Plan your defence.

**Problem 2:**

Dlr: East ♠ 7  
 Vul: Nil ♥ KQ1076  
 ♦ AK4  
 ♣ 10972

N	♠ KJ92
W	♥ 2
E	♦ Q986532
S	♣ 4

West	North	East	South
Pass	5♣	All Pass	3♣

Partner leads ♠A. How will you defend?

Solutions on page 7.



**Suit Combination of the month**

AJ10876  
 □  
 K

Play the king and overtake it with the ace, then play the jack. This works if the 9 drops within the first three rounds. This is much superior to winning the king and then using your entry to play the ace, which requires the queen to drop in two rounds.

## CONGRESS RESULTS

### Tricks & Trumps

#### Swiss Pairs

- 1 G. Hill – J. Tunks
- 2 D. Harley – A. St Clair
- 3 J. Howard – S. Hawkins

#### Restricted Swiss Pairs

- 1 A. Roberts – J. Rennie
- 2 M. Simons – R. Bourne
- 3 H. Rogers – Z. Radovic

#### Swiss Teams

- 1 K. Muntz, H. Blakeman, A. Krolikowski, R. Stewart
- 2 C. Arul, G. Neale, J. Eddie, L. Szabo
- 3 A. Hegedus, A. Mill, J. Howard, A. Maluish

### Eastern Region Congress

#### Swiss Pairs

- 1 J. Anderson – C. Van Lier
- 2 J. Banks – A. Kieron
- 3 F. Power – G. Campbell

#### Swiss Teams

- 1 J. Farmer, J. Gladders, P. Beck, L. Munro
- 2 A. Drury, J. Kuiper, G. Barbour, G. Nicholson
- 3 R. Owen, R. Key, D. Wallace, L. Smark



Winners of the ERBA Swiss Pairs, Jeanne Anderson and Corrie Van Lier, with director Martin Willcox

### Dendy Park

#### Swiss Pairs

- 1 M. Darling – B. Kingham
- 2 J. Masters – T. Cowie
- 3 S. Sharp – D. Sharp

### Yarra Valley Super Congress

#### Swiss Pairs

- 1 A. Mill – A. Macready-Bryan
- 2 G. McRobert – T. Ranasinghe
- 3 J. Thompson – B. Thompson

#### Swiss Teams

- 1 S. Klofa, R. Gallus, G. Ridgway, P. Jain
- 2 S. Thorne, K. Thorne, B. Ulyatt, M. Petrie
- 3 K. Bailey, N. Ewart, D. Newlands, G. Bailey

### Queen's Slipper Nationwide Pairs

#### Event 1 (January 4)

- 2 Cecile Senior – Gwenda Mealyea (Waverley)

#### Event 2 (January 19)

- 1 Helen McKnight – Alex Smith (Ballarat)
- 2 Chris Turner – Bryan Fuller (Echuca)
- 3 Pam Dingwall – Sandor Varga (Bairnsdale)

#### Event 3 (February 1)

- 1 Alex Smith – Denise Newland (Ballarat)
- 3 Yvonne Minton – Bobbi Burton (Frankston)

#### Event 4 (February 16)

- 3 Patricia Dungey – Ethna Ramage (Bendigo)

### Australian Women's Team Playoff 2014

Congratulations to Felicity Beale and Diana Smart, who won the recent Australian Women's team playoff in Sydney. They are surely the longest standing international-level Australian women's pair ever, and show no signs of flagging.



Diana Smart and Felicity Beale

## UPCOMING CONGRESSES

### Rye Beach

Saturday 15<sup>th</sup> March 10 am: Swiss Pairs  
 Sunday 16<sup>th</sup> March 10 am: Swiss Teams

Venue: Rye Civic Hall  
 12 Napier St  
 Rye (Melway 168F4)

Contact: Brian Morgan, 0439 845 753

Enter: [www.bridgeunlimited.com](http://www.bridgeunlimited.com)

### Donald

Saturday 22<sup>nd</sup> March 2 pm: Swiss Teams  
 Sunday 23<sup>rd</sup> March 10 am: Swiss Pairs

Venue: Donald Golf Course  
 Wood St  
 Donald

Contact: Brian Brasier, 03 5497 1019

Enter: [www.bridgeunlimited.com](http://www.bridgeunlimited.com)

### Wodonga

Friday 28<sup>th</sup> March 7 pm: Welcome Pairs  
 Saturday 29<sup>th</sup> March 10 am: Swiss Pairs  
 Sunday 30<sup>th</sup> March 10 am: Swiss Teams

Venue: Student Association Building & Cafe  
 University Drive  
 La Trobe University  
 West Wodonga

Contact: Richard Harman, 03 5728 3232

Enter: [www.bridgeunlimited.com](http://www.bridgeunlimited.com)

### Whittlesea

Sunday 6<sup>th</sup> April 10 am: Swiss Pairs

Venue: Whittlesea Show Grounds  
 Administration Building  
 29 McPhees Rd  
 Whittlesea (Melway 246H7)

Contact: Lyndall Shaw, 03 5786 1839

Enter: [www.whittlesea.bridgeaustralia.org](http://www.whittlesea.bridgeaustralia.org)

### Frankston

Saturday 12<sup>th</sup> April 10 am: Swiss Pairs  
 Sunday 13<sup>th</sup> April 10 am: Swiss Teams

Venue: St Francis Xavier Centre  
 Cnr Baxter & Davey Streets  
 Frankston (Melway 102D3)

Contact: Yvonne Minton, 0418 348 264

Enter: [www.bridgeunlimited.com](http://www.bridgeunlimited.com)

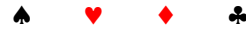

## COUNCIL NEWS

### VBA Special Councillor Elections

At the close of the nomination period for Special Councillor positions, the VBA had received nominations from the following:

**Pam Dingwall**, Bairnsdale Bridge Club:  
Country East

**Sarah Livingston**, Dromana Bridge Club:  
Metro Arc

**Rob Quirk**, Waverley Bridge Club: Metro near  
VBA

There being no other nominations, as per the regulations, the above nominees are declared elected.

No nominations were received for Country West, so this position remains as a Casual Vacancy which may be filled at a later date under the rules governing casual appointments.

The VBA Council congratulates Pam, Sarah and Rob on their appointment.

### Teacher Training Seminar

Joan Butts is in Melbourne to host a Teacher Training Seminar at the VBA over the weekend of March 29/30. This is a free seminar open to all affiliated bridge club members. Registrations may be made with Cathie Lachman at the VBA phone 9530 9006, or email to [info@vba.asn.au](mailto:info@vba.asn.au). More details are available on the VBA website.

**RECENT MASTER PROMOTIONS**

**State**

Vic Burton	Echuca
Lanny Chan	Moonee Valley
Ronald Crick	Yarra Valley

**\*State**

Bryan Fuller	Echuca
Isia Nowicka	Moonee Valley
Hilma Suren	Frankston
Ian Wright	Yarra Valley

**National**

Fatma Ahmet	Moonee Valley
Ant Edwards	Waverley
Ilse Porritt	Bairnsdale

**\*National**

Jaroslav Mychajlyszyn	Yarra Valley
Roger Walker	Phillip Island

**Grand**

George Lovrecz	Melbourne
Frank Power	Bairnsdale

**Gold Grand**

Ben Thompson	VBA
--------------	-----

**PUZZLE CORNER**

This deal, which came up in the recent American Reisinger nationals contains a curiosity – see if you can spot it.

♠ -			
♥ 10			
♦ K109876543			
♣ 942			
♠ 108543			♠ AQJ72
♥ 832			♥ AQ7
♦ A			♦ QJ2
♣ AQ65			♣ K10
	♠ K96		
	♥ KJ9654		
	♦ -		
	♣ J873		

E/W play 6♠. As the N/S pair, what are your chances of defeating this contract? See the bottom of the next column for the solution.

Congratulations to Ellena Moskovsky, who won the Bronze Life Master section of the 2013 McCutcheon awards.

**SETTING TRICK – SOLUTIONS**  
**Ian McCance**

**Problem 1**

Dlr: West	♠ J76
Vul: Nil	♥ 103
	♦ A10872
	♣ KQ10
♠ -	
♥ KJ942	
♦ KJ543	
♣ A72	

	N	
W		E
	S	

♠ K543
♥ AQ7
♦ Q96
♣ J95

♠ AQ10982
♥ 865
♦ -
♣ 8643

This deal is an open book. Partner's hand-shape is very likely 0553 and his/her holding in the reds KJ. You should make 2 tricks in hearts and partner's ♣A. You must ensure a fourth trick by forcing dummy to ruff a heart. You can plan to play ♥A, ♥Q, then ♥7 but it might be safer to win trick 1 with ♥Q in case partner is tempted to overtake ♥Q at trick 2.

**Problem 2**

Dlr: East	♠ 7
Vul: All	♥ KQ1076
	♦ AK4
	♣ 10972
♠ A8543	
♥ AJ954	
♦ J	
♣ Q6	

	N	
W		E
	S	

♠ KJ92
♥ 2
♦ Q986532
♣ 4

♠ Q106
♥ 83
♦ 107
♣ AKJ853

Partner is likely to have ♥A. All you need to do is persuade her/him to play it, then another heart. Playing ♠K on ♠A should be very persuasive.

♠ ♥ ♦ ♣

**Solution to Puzzle Corner**

If *West* is declarer, North can lead any card in his hand and beat 6♠. But if *East* is declarer, South can lead any card in his hand and the contract will make.



## 2014 VICTOR CHAMPION CUP BRIDGE FESTIVAL



**10AM DAILY- THURSDAY 5<sup>TH</sup> JUNE – MONDAY 9<sup>TH</sup> JUNE 2014**

Bayview Eden Hotel 6 Queens Road, South Melbourne Victoria

### SWISS PAIRS EVENTS

WOMENS, SENIORS, OPEN, RESTRICTED, AND <50 MP 5<sup>TH</sup> JUNE -6<sup>TH</sup> JUNE

SWISS TEAMS: OPEN & RESTRICTED

7<sup>TH</sup> JUNE –9<sup>TH</sup> JUNE

NEW FOR 2014 - WARM-UP WITH SPEEDBALL JUNE 4<sup>TH</sup> @8PM

An ABF Gold Point and Playoff Qualifying Points Event

For more details and to enter visit the website: [www.vba.asn.au/vcc](http://www.vba.asn.au/vcc)

## Teacher Training Program



Australian Bridge Federation Inc.

## Victorian Bridge Association

**29, 30 March 2014**



ABF National Teaching  
Coordinator - Joan Butts

### EDUCATION PROGRAM – BRIDGE TEACHERS

#### Saturday 29 March 2014 VBA

When	Topic
10.00 – 1.00	<b>Teaching Methodology</b> Generating STEAM – a focus on five essentials for professionally delivered bridge lessons
1.00 – 1.30	<b>Lunch</b>
1.30 – 3.00	<b>Practical Teaching Tools (1)</b> Up-to-date methods that assure successful lessons for players from beginners to advanced
3.00 – 3.15	<b>Afternoon tea</b>
3.15 – 4.00	<b>Practical Teaching Tools (2)</b>

#### Sunday 30 March 2014

When	Topic
10.00 – 12.00	<b>Demonstration Workshop Joan Butts</b>
12.00 – 1.00	<b>Discussion Group with Teachers</b>

If you are a bridge teacher, or would like to become one, attend this **free** workshop, sponsored by ABF& VBA

You're welcome to do the course more than once. The workshop will follow a modern approach to teaching, both in theory and in practice.

You will receive a Teacher Training Certificate if you attend all 9 hours of the course.

NB: BYO Lunch. Coffee etc will be provided.

**Where: VBA**  
131 Poath Rd, Murrumbeena  
03 9530-9006

**To Register:**  
Cathie Lachman  
[clachman@vba.asn.au](mailto:clachman@vba.asn.au)